

# Fully automatic PALLETISER

## Model: MK4

Palletising robot for palletising plastic boxes

- › Fast, simple and reliable
- › Good ROI
- › Increased productivity
- › Minimal space requirements
- › Improved work environment, reduced noise level, and better staff retention

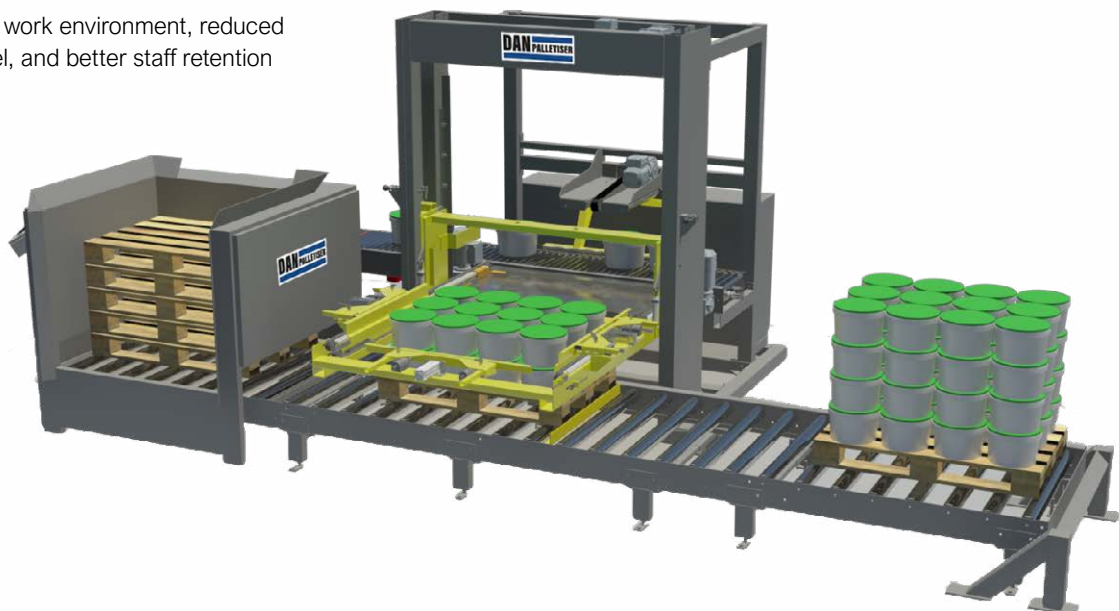

# Fully automatic PALLETISER

Model: MK4

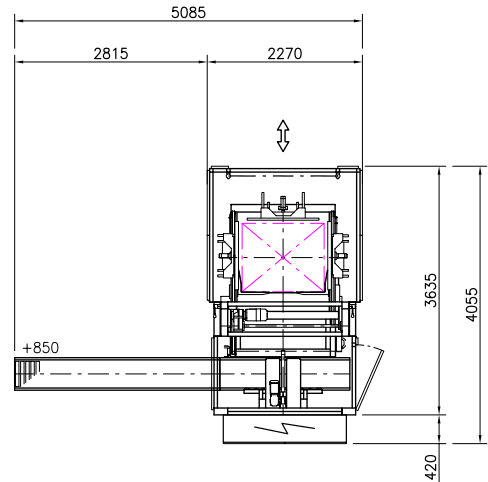

## MK4 can palletise:



Conical buckets



Boxes



Plastic tubs



Drums



Cans

## Configuration

An MK4 is specially designed to palletise round or square buckets and cans, but it can also palletise boxes. It is, therefore, ideal for manufacturers of paint that produces both large buckets that are placed directly on the pallet and smaller cans that come in boxes before palletisation.

An MK4 palletiser can palletise EUR pallets, ½ pallets, ¼ pallets, and industrial pallets (1000×1200mm). It can palletise up to 240 rows per hour, and you can choose from and configure 25 different pallet patterns using the operator panel.

An MK4 palletiser is small and compact and does not require much space. It is modular, meaning you can choose different accessories according to your needs and how much space you have available.

For example, it can be equipped with automatic handle control to ensure that the handles always face the same way. It is designed to fit neatly in its surroundings. Inlet and outlet conveyors can be assembled, angled, raised and lowered in a number of ways, so even if you have limited space, there is a good chance the MK4 can fit.

## CONFIGURATION

Capacity	120 pallet layers/hour
Pallet size	EUR pallets, ½ pallets, ¼ pallets, and industrial pallets (1000×1200 mm)
Pallet patterns	25 configurations



See the MK4 pallet loader in action here

Palletisation of plastic tubs

Palletisation of buckets

## Function

The products come from a filling machine or packing machine via an inlet conveyor and are run further into the palletiser. When one row is assembled a pusher arm pushes it further onto the pallet.

The pusher arm is provided with a plastic rail that has the same shape as the round product being palletised. This ensures that the product stays where it needs to be.

The rows are adjusted automatically, so the products align correctly. The pallet can then be wrapped, driven to a warehouse and safely transported to the customer.

At no time the product is lifted, raised or pulled, so there is no risk of the lids coming off. This makes the palletiser the most gentle form of palletisation.

## PRODUCTS

Max weight	250 kg / pallet layer
Max pallet height	2300 mm
Max box size	800 mm diagonal

## Semi- or fully automatic

MK4 is available in both a fully automatic and a semi-automatic version.

- › With the semi-automatic model, a pallet lifter drives the pallet into the palletiser and removes it again the same way when palletised.
- › With the fully automatic model, the empty pallets run from the pallet magazine via a conveyor into the palletiser.
- › When palletised, it runs via a conveyor to the pick-up place.

## In-house production

Experienced mechanical and electrical engineers at DAN Palletiser construct the machine which is manufactured and assembled in our workshops. The palletiser control is also built and programmed at DAN Palletiser.

All machines are assembled and tested and are approved by the customer before delivery, to ensure everything works as it should.

We deliver the palletiser on site, we install it, do the commissioning and train the staff so that they are able to operate it themselves.

Our service department offers various types of service agreements, so we can maintain the palletiser regularly, ensuring that it always runs optimally. We also provide 24-hour assistance if needed.

## DAN Palletiser A/S

Industrivej 12  
DK-4241 Vemmelev  
+45 58 38 21 93  
[www.dan-palletiser.dk/en](http://www.dan-palletiser.dk/en)

